

SPHERICAL

DO3-51-3084-SH215T-V171202

Page 1/1

DESCRIPTION

- Aesthetic with high performance spherical speaker.
- Moulded white colour ABS. Other colours on request.
- Dual cones wide band silicon treated speaker.
- Impregnated low insertion loss multi-taps transformer.
- Hanging
- Suitable for high ceiling areas and Indoor use.



TECHNICAL SPECIFICATIONS

Nominal Power (100V)	Watts	15
Maximum Power	Watts	30
Frequency response	Hertz	90-18000
SPL (max) 1W@1m	dB	92-(104)
Connection	4 Wires cable	
Power Selector (100V)	Watts	15/8/4
Impédances	Ohms	0,7/1,25/2,5K
Pack dimensions : WxHxD	mm	210x210x210
Pack Weight	Kg	1,6

WIRING

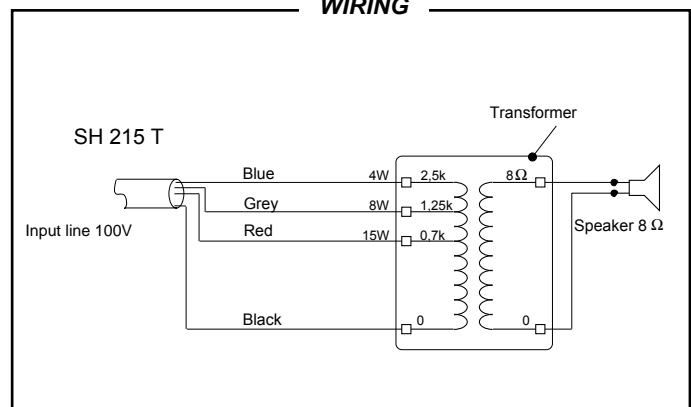

DIMENSIONS

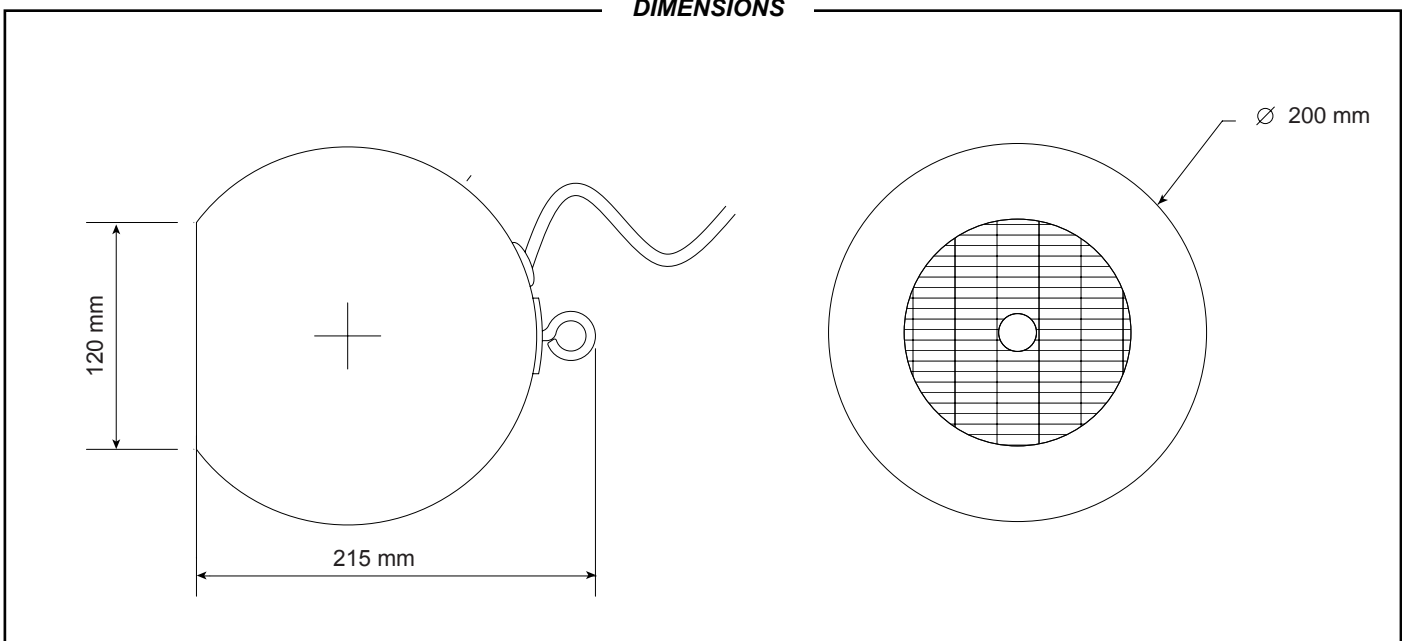

MERLAUD

9 rue de La Briqueterie - P.A.E. des FAUVETTES - 95334 DOMONT CEDEX (FRANCE)
 Tel. 01 39 91 77 78 - Fax 01 39 91 90 66 - www.merlaud.com - merlaud@merlaud.com

SPECIFICATIONS SUBJECT TO MODIFICATIONS